



2010 Rules & Regulations 1300 cc STOCKCAR

Contents

1. THE FORMULA.....	2
2. ELIGIBLE CARS	2
3. VIOLATIONS.....	3
4. PERSONAL SAFETY	3
5. SAFETY EQUIPMENT	4
5.1 CRASH HELMET	4
5.2 RACING OVERALLS	4
5.3 GLOVES	4
5.4 BALACLAVAS.....	4
5.5 A NECK BRACE.....	4
5.6 WET WEATHER CLOTHING	4
5.7 WINDOW NET	4
5.8 1kg FIRE EXTINGUISHER	4
5.9 COMPETITION STYLE DRIVERS SEAT WITH HEAD RESTRAINT.....	4
5.10 SAFETY HARNESS	5
6. ROLL CAGE.....	6
7. UNDER IRONS	7
8. FRONT & REAR BUMPERS.....	7
9. SIDE IRONS	7
10. FRONT WHEEL PROTECTION.....	7
11. REAR WHEEL PROTECTION	8
12. WHEELBASE.....	8
13. VEHICLE WEIGHT.....	8
14. FRONT SUSPENSION	8
15. REAR SUSPENSION.....	8
16. THE STEERING.....	8
17. THE SPRINGS.....	9
18. RIDE HEIGHT	9
19. FRONT SHOCK ABSORBERS	9
20. REAR SHOCK ABSORBERS	9
21. WHEELS & TYRES.....	9
22. FINAL DRIVE	9
23. GEARBOX & PROPELLER SHAFT	9
24. BRAKES.....	10
25. ENGINE	10
26. ENGINE SEALING	10
27. OIL CATCH TANK.....	11
28. COOLING SYSTEM.....	11
29. IGNITION SYSTEM - DISTRIBUTOR	11
30. CARBURETTOR & INLET MANIFOLD	11
31. FUEL SYSTEM	11
32. EXHAUST SYSTEM.....	13
33. BATTERIES & THE ELECTRICAL SYSTEM	13
34. TRANSPONDER.....	13
35. MIRRORS	13
36. BODYWORK.....	13
37. PAINTWORK.....	13
38. SUN VISOR	13
39. FIN PLATES.....	14
40. DOOR NUMBERS.....	14
41. ROOF GRADING	14
42. SPECIFICATION AND RULE CHANGES	14
43. SCRUTINEERING OF NEW CARS	14

1. THE FORMULA

The object of the race is to complete the specified number of laps in the shortest time. You may push a car from behind or spin a car to the inside of the circuit. You must not lean or spin a car into the safety fence or deliberately follow a car into the safety fence on the entry to a bend (whether from the rear or side of the car). Attacking the car from the safety infield is also not permitted.

Actions deemed to be deliberate or dangerous will carry penalties.

Racing is in a clockwise direction on a clearly defined circuit with a separate infield. Any wheels passing over the demarcation lines or entering on to the grassed infield areas will mean that the driver will be penalised.



2. ELIGIBLE CARS

Any 1300cc Carburettor fuelled, metal bodied, four -seater saloon or hatchback as listed below. Drivers wishing to race alternative vehicles must contact the Promoter.

Vehicle Make & Model	Engine Capacity	Carburettor Venturi Diameter
Citroen AX 11	1124cc	25mm
Colt Lancer	1288cc	21/27 mm
Colt	1200cc	21/27mm
Datsun Sunny 1300	1296cc	20/26 mm
Fiat Uno	1299cc	19/23mm Weber 30/32mm
Ford Ka	1300cc OHV or CVH	23/24mm ohv 24/25mm cvh
Ford Fiesta Mk 2-5	1300cc OHV or CVH	23/24mm ohv 24/25mm cvh
Ford Escort Mk 1-3	1300cc OHV	23/24mm
Ford Escort Mk 3	1300cc CVH	24/25mm
Mazda 323	1300cc	21/27mm
Peugeot 205	1294cc (OHV engine only)	36 DCN VH17 Weber or 26 Weber 321 BSH
Toyota Corolla 1300 DX	Must use the standard 1200cc carburettor	21/24mm
Toyota Corolla SR Coupe		18/24mm
Toyota Starlet 1.3	1290cc (Must use 1200cc carb)	21/24mm
Vauxhall Nova, Corsa, Tigra		21/23 or Peirburg 2E3 20/24mm
Volkswagen Golf, Polo, Passat		21/23 or Peirburg 2E3 20/24mm

3. VIOLATIONS

1. When referring to the engine, gearbox, final drive, mechanical or construction Rules & Regulations, the principle will always be: Unless permission is specifically granted to make modifications (or any variation) nothing may be done to alter or change the Standard Parts in any way.
2. It is the responsibility of the Driver to prove to the Promotion that the part is legal, by way of written proof of where the part originated. This must be undertaken within 7 days, otherwise the item in question will be deemed illegal, resulting in immediate suspension from racing & referral for disciplinary action. **Unless the rules say you can do it, you cannot do it!**
3. Presentation of a Vehicle for Scrutineering is a declaration by the entrant that the vehicle is eligible for that event.
4. Car engines & fuel will be checked on a random basis. Violations or refusal to allow an engine check will result in an immediate suspension of all racing facilities.
5. All Car and Engine Specifications will be taken from either the manufacturers Technical Specifications or the Technical Service Data books as published by Glass's Guide.
6. Should a discrepancy occur between the Specifications then the Promotion will exercise its judgement, and that decision will be final.
7. Clarification on any one item may be sought from the Promoter.
8. Each driver is permitted one car per meeting & each car is permitted one driver per meeting.

4. PERSONAL SAFETY

Drivers are advised that under Health & Safety, they are responsible for their own and their Mechanic's actions. Promoters have had complaints made about Registered Drivers & Mechanics consuming large amounts of alcohol at meetings, which could effect their judgement or be detrimental to their health, when medical attention has to be administered by Paramedics, St Johns or Hospital Staff. Should an incident occur that proves fatal on the raceway and you are involved, it is likely that the Police will want interview you. **If you drive, don't drink!** Scrutineers and Officials will report to the Clerk of the Course, anybody they believe is under the influence of Drink or Drugs. Drivers whom it is thought are under the influence may be breathalysed. You have been warned!

It is also apparent that some drivers are not aware of the flags used by the track staff so here is a reminder:

- Waved Green Flag – Go, the race is on.
- Waved Red Flag – Stop racing slow down & stop.
- Chequered Flag – Race winner has crossed the line, continue to race until the Red Flag is shown.
- Held Yellow Flag – Beware, you are approaching a hazard on the track, continue to race.
- Waved Yellow – Slow down to 15mph, hold your position, and do not overtake any other cars.
- Waved Blue Flag – Shown to a driver who must hold his racing line. Driver must either hold a line on the inner part of the track or the outer part of the track, not weave between both.
- Blue & White Flag – Give up your track position, you have not taken notice of the Blue flags.
- White Flag with a Blue spot – Oil on the track.
- Waved Black Flag - You are disqualified, pull off the track immediately.
- Black cross on a White board – You have committed an infringement and may be penalised in the results.

Drivers are also reminded that they should line up on the grid with their engines switched off in the correct points order, unless told otherwise.

5. SAFETY EQUIPMENT

5.1 CRASH HELMET

A Crash Helmet having a minimum specification as detailed by the British Oval Racing Safety Executive (BORSE). **Shatterproof** visors or goggles must be worn for racing or practice. Tinted visors are not advisable. **Your helmet must display the current ORCI (ORC09) sticker.**
It is important that the helmet fits the driver correctly.

Polycarbonate (Plastic) helmets of any type are not permitted.

Helmet minimum specification : (as detailed by BORSE)		
FIA		8860- 2004
British Standards Institute	1	BS6658 - 85 Type A
Great Britain	2	BS6658 - 85 Type A FR
The Snell Foundation	1	SA2000 - SA2005
USA:	2	SF1 Foundation 31.1A or 31.2A
The European E22 Standard	1	With Serial Number starting 05
:	2	Fibre Glass or Fibre Glass/KEVLAR Or Tri - Composite form only

5.2 RACING OVERALLS

You must wear Fire retardant, clean, un-torn and brightly coloured Racing Overalls that are made of a fire retardant material and are clearly marked fireproof. Mechanics are also required to wear clean overalls and will not be permitted on to the track without them being on, when instructed to do so.

5.3 GLOVES

It is Mandatory to wear Fire retardant Gloves also clearly marked fireproof.

5.4 BALACLAVAS

It is Mandatory to wear Fire retardant Balaclavas clearly marked fireproof.

5.5 A NECK BRACE is recommended but not compulsory, so to is a spine support.

5.6 WET WEATHER CLOTHING is also recommended and must be worn in addition to, and **not** instead of the racing overalls.

5.7 WINDOW NET

You must have a cloth type Window Net with a maximum spacing of 76mm x 76mm, which must be fitted with a quick release mechanism.

5.8 1kg FIRE EXTINGUISHER

A 1Kg Dry Powder Gauge Fire Extinguisher is highly recommended and if fitted, this should be in a tube with a spring top and should be within easy reach of the driver. Old type BCF (green) type extinguishers are not allowed. All tow vehicles, must carry a minimum of a 2kg fire extinguisher dry powder or gas, which must be within easy reach of the driver and mechanics at all times, especially when refueling.

5.9 COMPETITION STYLE DRIVERS SEAT WITH HEAD RESTRAINT

You must have a Competition type Driving Seat with a head restraint. The seat should occupy its original position where possible and be suitably supported at shoulder height and on both of the sides and back, with a suitable framework or seat stiffener's.

Additional wrap around seat support at shoulder height.

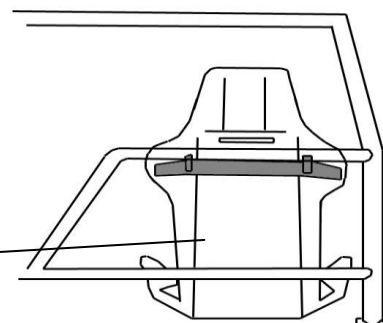

5.10 SAFETY HARNESS

The lap belt/straps and crotch straps should not pass over the sides of the seat, but through it, in order to wrap and hold the pelvic region over the greatest possible surface

It is mandatory to have a 5 point Safety harness with 3" shoulder straps, the lap & crutch straps can be either 2" or 3" in width.

All seatbelt connection points must be visible and no belts must pass through any firewall.

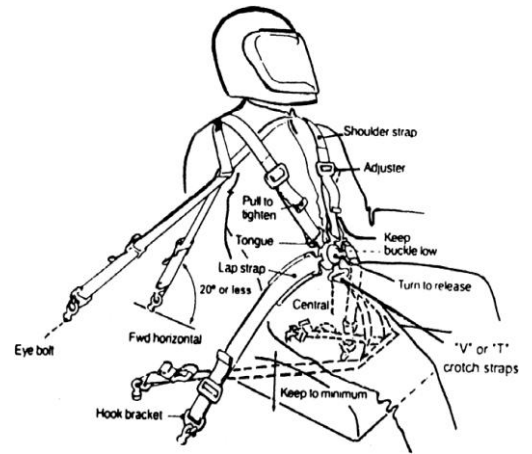

Following research made by leading safety harness manufacturers, information has been made available with regard to the best way to fit your safety harness; this will further ensure your safety. Please study the diagrams to ensure your safety harness is fitted correctly.

The lap belt crossing should be below the anterior-superior iliac spines (bony part of the hip). Under no circumstances should it be worn over the region of the abdomen.

Lap belt/straps **must terminate vertically downwards**, and not forwards or rearwards of the hip joint. Lap straps should terminate symmetrically about the wearer on either side of the seat, about 20" (500mm) apart. The distance between the seating surface and the anchorage point should be kept to a minimum to prevent submarining. The location of the crotch strap mounting should be to the rear of the driver.

Fig.1 shows the location for the tail straps, which should be horizontal to 20° below horizontal, and as close to the shoulder as is practical for optimum restraint.

Only safety belts comprising of separate shoulder, lap, and sub-straps will be permitted.

The sub-strap must be used at all times, and all belts must connect to the quick release buckle. The abdominal strap fixing point must be on the chassis, roll cage, or floor (for vehicles with no chassis), either side of the driver.

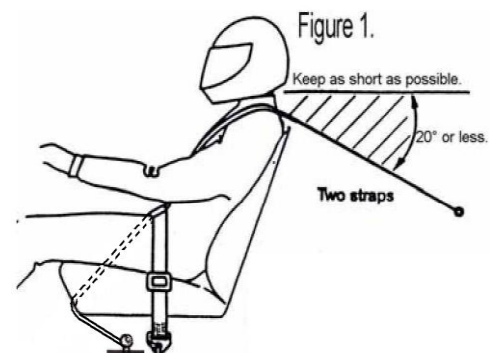

The shoulder straps must be supported at shoulder height. NASCAR type buckles must be fitted with lever on the **right** side of the driver. It is advisable to fit a secondary means of detent to prevent overall sleeves accidentally unhooking the buckle during racing. A small section of tube grip **elasticated** bandage, slid over the hooked buckle, serves the purpose.

Special attention must be paid to the condition of seat belt fixings once fitted. Information is available, from your Promotion, on the correct procedure to follow when fitting seat belts. *Remember - your life depends on them, and belts, once involved in a severe accident, should be discarded and replaced.*

Over the years, we have had many unnecessary injuries due to badly fitted seats. They frequently occur in Non-contact Formulas, when perhaps a driver believes it is more unlikely that he will be involved in a serious crash, and he also believes that, if he is involved in a collision, the impact on his car will be from the front. However, this is often not the case. It is therefore, imperative that you ensure your seat is really well supported, especially where the shoulder straps go through. You must also ensure that your seat cannot move sideways.

The safety of your seat will be judged by the Scrutineer's and you will only be permitted to race when they are satisfied that you will be as safe as possible in any event.

6. ROLL CAGE

Key: SHS - Square Hollow Section.
RHS – Rectangular Hollow Section
CHS – Circular Hollow Section

The roof may be removed to aid welding and fitting of the cage, but it must not be lowered or shortened when refitted. The roll cage must be constructed from either 38mmx38mm or 40mmx40mm SHS or CHS, with a wall thickness of 3 to 3.5mm & it must support both the A & B pillars. The cage must consist of the following minimum iron work.

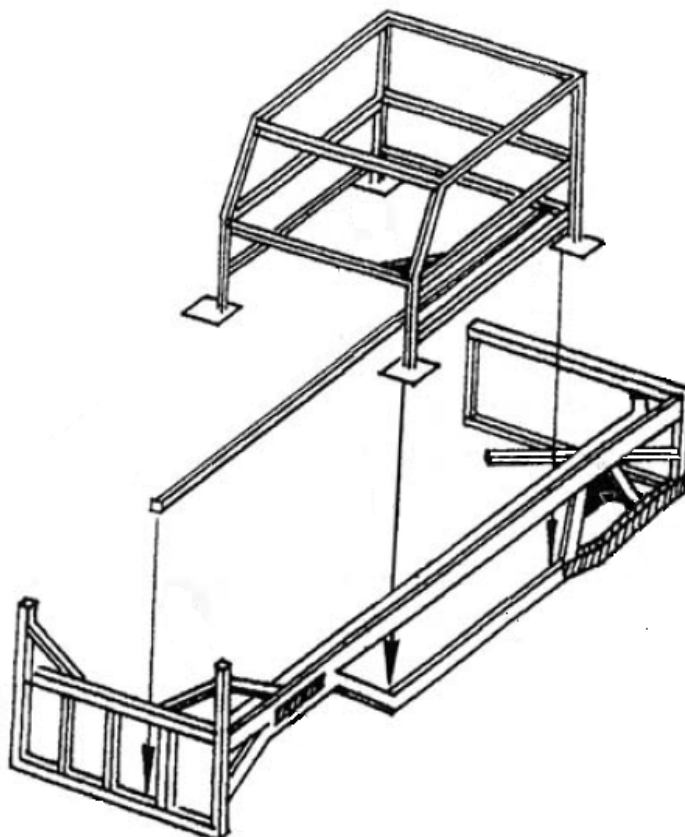

1. One front hoop over the A posts.
2. One rear hoop over the B posts.
3. Two cant rail roof bars connecting the A&B hoops, **with an additional third central roof bar.**
4. A 3mm plate is to be welded on all four sides on top of the roll cage frame above the driver.
5. The roll cage hoop feet must be welded to four 3mm thick plates 100mm square or alternatively **welded to the chassis.**
6. There must be one front crossbar **at dash height.**
7. There must be two crossbars behind the driver, one of which must be at shoulder height to support the seat.
8. Both front doors must have two chicken bars spaced 300mm apart, **linking the A&B posts.**
9. Both front doors must have a 3mm thick plate welded on the outside of the chicken bars, and may substitute the original outer body panels between the front & rear wheels. Alternatively if the original outer panels are used the 3mm plate needs only to be a minimum of $\frac{2}{3}$ of the width of the door, **placed centrally between the A&B posts.**
10. It is compulsory to weld a 3mm thick driver's floor plate from just below the pedals to the rear of the driving seat.
11. A metal up-right made from a maximum of 38x38mm or a minimum 19x19mm by 2 to 3mm thick SHS must be welded or bolted to the centre of the front windscreen aperture. No wire mesh is permitted in front of the driver in this area.

12. Additional ironwork is permitted inside the car but it must not go "straight through" there must be a break of 150mm or 6" front to rear by either stepping, diverting or angling the iron work.
13. It is also permitted but not compulsory, to fit a brace off the upper passenger door chicken bar to the dash cross bar. This single bar made of 38mmx38mm or 40mmx40mm by 3mm thick SHS must go no further back than the centre of the front passenger door window aperture.
14. A single bar of 38mmx38mm or 40mmx40mm by 3mm thick SHS may be fitted from the nearside front lower bumper iron to the rear roll cage hoop cross bar. This bar & any connecting iron work must not be above the lower door chicken bar inside the confines of the roll cage.
15. Corner gussets of 150mm triangles are permitted but there must be no overlapping of the gussets.
16. Any part of the cage coming in to contact with the driver must be padded.

7. UNDER IRONS

1. All iron work must be between 2.5 to 3.5 mm in thickness unless otherwise stated.
2. The under irons must be made of either 38x38mm, 40x40 mm SHS or 50x25mm RHS iron and may be cross-braced. They may also be connected to the internal iron work.
3. Under irons must follow the chassis rails or floor and must not come above them at any point. An exception to this rule would be when a piece of floor running next to the chassis is lower than the chassis rail, then it may be pushed up level with the top of the chassis member or cut out.
4. The under irons may pass under or over the axle, cross member or subframe.
5. Subframes may be mounted to the under irons.

8. FRONT & REAR BUMPERS

1. The bumpers must be constructed of 38x38mm, 40x40mm SHS or 50x25mm RHS iron with a maximum thickness of 4mm & consist of 4 or 5 equally spaced uprights between the horizontal cross-bars.
2. The bumper horizontal cross bars must be spaced 360mm apart top to bottom.
3. The bumpers may have straight or angled ends. If it is the latter, then 305mm or 12" from each end of the bumper the iron work can be angled back 150mm or 6" towards the wheels.
4. The front bumper must have hoops on both of its ends. The end uprights must have a minimum height of 80mm or 3" above the top horizontal cross-bar and the diagonal must go no further than the second front upright. A diagonal brace going back off the end upright must go no further back than the centre of the front wheel.
5. There should be a maximum of three pieces of iron joining each bumper corner.
6. **A rubbing iron made from 50x25x3mm RHS iron may be welded to the fence side front bumper upright only. Please ensure that the welding of this rubbing iron has full penetration & the 50mm side of the iron is against the side of the upright.**

9. SIDE IRONS

1. All side irons must be constructed from 50x25x 3 or 4mm thick RHS iron.
2. The side irons must be no less than 300mm apart.
3. The removal of the original panels in this area is permitted, but when they are left in place, a 3mm thick plate must be welded to the outside of both of the doors chicken bars. This plate need only cover the central $\frac{2}{3}$ of the door apertures. See Roll cage 6.9.
4. When the outer panels are removed, the 3mm plate should be positioned behind the irons to infill the area between the side irons from the front to the rear wheels, substituting the outer panels.

10. FRONT WHEEL PROTECTION

1. A single piece of iron either 38x38mm, 40x40mm or 50x25mm 3 to 4mm thick may be fitted centrally over both the front wheels, on the exterior iron work only, to protect the struts. The maximum length of this iron is 610mm & it must have rounded edges.

11. REAR WHEEL PROTECTION

The top part of the wheel rim must be covered to prevent the wheel breaking loose whilst racing and this may be done by one of two ways.

1. The lower side irons around the area of the rear wheel can have a frame made of 38x38mm or 40x40mm by 3mm thick SHS iron welded to them to stand off of the side irons by a maximum of 50mm or 2". The front of this frame should be angled so that it glances off other cars but the rear part of the frame may continue on to join the rear bumper.
2. A section of heavy duty leaf spring with a suitable angled mounting bracket (50mm maximum protrusion) is located so that the leaf is secured at the front of the rear wheel, with a slipper bracket fitted to the rear of the wheel. The leaf spring bolt should be no larger in diameter than 12mm & the leaf must be cold worked, no heating of the leaf is allowed. .

12. WHEELBASE

1. The wheelbase on both side of the car must be standard $\pm 25.4\text{mm}$ or 1" (***This means rather ½" or 12.7mm on both wheels or one wheel standard wheel base and the other one to a maximum of 1" \pm forward or backwards***).
2. When repairs have been made to the suspension using standard parts & the wheelbase is found to be incorrect, washers may be added or removed from the front tie-bars or anti-roll bars only to bring it within specifications.

13. VEHICLE WEIGHT

1. Cars may be checked (excluding the driver) at any time for there weight and they must weigh no less than 900kg, and no more than 1000kg.
2. Infringement of this rule carries a statutory ban from racing e.g. 1kg under or over is 1 month ban, 3kg is 3 months ban, and in excess of 3kg is a 6 month ban. Ballast is not permitted in the car.

14. FRONT SUSPENSION

1. To be fitted as original no interchanging of parts within the manufacturers range to change the suspension geometry. Whatever is fitted on the nearside must be fitted on the offside.
2. The exception to the above is that the Nearside track control arm may be lengthened by 25mm or 1". Track control arms will be checked for equal length plus 25mm.
3. The NSF top suspension mounting may be repositioned to achieve negative Camber & Castor & be strengthened. The geometry settings must not be adjustable.
4. The OSF suspension top mounting may be strengthened only, but **no** positive camber is allowed.

15. REAR SUSPENSION

1. Must remain as standard & to manufacturers settings. Distorted axle beams must be reset with hydraulic equipment.
2. Race cars that have suffered damage or corrosion may strengthen or attach any suspension pick up point to the iron work, but the pickup point must be in its original position.
3. Toyota Starlet link arms may be substituted for bars and bushes of a different size but the centres must be as the manufacturer's original dimensions.

16. THE STEERING

1. No quick racks can be used
2. A quick release steering wheel is permitted.
3. Steering column height may be adjusted to suit the driver & the upper bracket strengthened.

17. THE SPRINGS

1. Springs are free **BUT YOU CAN NOT FIT** 57mm or 2¼" diameter competition type.
2. Only one spring is allowed per corner.

18. RIDE HEIGHT

1. This is measured without the driver, from the bottom of the sill (not the rebate lip) to the ground, and this ride height measurement must be no lower than 178mm or 7". The test block must travel freely along the length of the sill between the front & rear wheels.

19. FRONT SHOCK ABSORBERS

1. The front Shock absorbers must be available to everyone, through recognised outlets at a maximum cost of £85.00 plus VAT.
2. No gas shock absorbers are allowed.
3. The shock absorbers must have NO exterior means of adjustment.
4. The casing must be original to the car or a replica of the original.
5. Spring platforms cannot be adjustable & must be in their original position.
6. Shock absorbers must mount in their original position using the original fixing method.
7. Locating holes must not be elongated or repositioned.
8. Fixing bolts must be original in size, so as not to allow for any movement or angle change.

20. REAR SHOCK ABSORBERS

1. Any standard production shock absorber, from any manufacturer that fits to the original mounting position without modification.
2. No competition types are allowed.

21. WHEELS & TYRES

1. Any standard 13" steel wheel can be used up 5½" in width.
2. No alloy or competition wheels are permitted.
3. Tyres must be of the following:
 - Kingpin Pacers (no soft road compounds)
 - Colway Remoulds (with the Spedeworth marking) 175/70R13
 - Yokohama AA01 A/Drive T rated 175/70-13.
4. Mud & Snow/Alpine versions are not permitted.
5. Tyre buffing is permitted.
6. Tyre softener is not permitted.

22. FINAL DRIVE

1. You must use the standard axle for the car if it is a rear wheel drive car and you may change the final drive ratios but these must come from the same manufacturers range without machining or modifications to the standard part.
2. Front wheel drive cars are allowed to change the final drive ratio from the same manufacturers range without machining or modifications to the standard part.
3. You must lock the differential by welding only.
4. No limited slip differentials are allowed.

23. GEARBOX & PROPELLER SHAFT

1. The gearbox must remain as standard with all the gears, but ratios from the same manufacturer can be interchanged, but it must be without machining or modification of the standard parts.
2. The gearbox mounts may be solid but they may not be repositioned
3. Rear Wheel Drive cars can interchange propeller shafts from within the manufacturers range
4. Front Wheel Drive cars can use any drive-shaft from within the manufacturers range.

24. BRAKES

1. To remain as standard as fitted by the manufacturer without modification.
2. Front Wheel Drive cars however, may bypass brake compensators.
3. Brakes must operate on all four wheels.
4. Handbrake must operate and lock both applied wheels.

25. ENGINE

1. The Engine must be standard to the car, the exception being the Vauxhall Corsa/Tigra, which must use the Nova specification engine.
2. All engine components must remain standard and not be interchanged between models with different engine sizes.
3. Toyota 3K & 4K engines must NOT use the cylinder head with the ports larger than 29mm.
4. The bores may be machined out to a maximum of 1.5mm oversize.
5. Cylinder head & piston combinations must be as manufactured.
6. The cylinder block may have its head gasket face skimmed only.
7. The maximum piston protrusion is 0.010".
8. Piston crowns must have their identification markings visible.
9. The cylinder head may be skimmed on its head gasket face only.
10. Head bolts may be shortened or washers used as spacers.
11. The head gasket cannot be modified in any way.
12. If the oil feed to the head becomes misaligned when the head is skimmed it may be re-aligned.
13. No welding may be done to the head either as repairs or modifications.
14. Valves must be standard
15. **Three-angle valve seats are permitted. The measurements of the three angle valve seats are as follows; Angle 1; Combustion chamber 30° - Angle 2; Valve seat 45° - Angle 3; Port 60—65° with valve seat width free.**
16. The original manufacturers' part, or any other manufacturers' standard or pattern replacement springs may be used (no competition types).
17. Rocker arms must be standard or pattern replacement. Vauxhall OHC engines are permitted to use the Diesel rocker as a replacement
18. The standard sump may be baffled
19. The oil pick-up pipe may be modified within the confines of the sump.
20. The engine position cannot be altered but the engine may be tilted to stop fuel starvation, **engine mountings may be solid and can be picked up from the iron work**
21. The engine may be restrained.
22. **You must use a standard flywheel and clutch to the engine the face maybe skimmed 1300 Vauxhall flywheel weight minimum 5kg and Toyota starlet flywheel 8kg not including the clutch or bolts.**

26. ENGINE SEALING

Spedeworth: We may at any time require your engine or other parts to be sealed. This may or may not mean your engine / parts will automatically be stripped or checked. It could be that we wish to monitor your performance or seek clarification on an item. It is normal to strip engines at all major championships unless they run consecutively in which case by agreement with Spedeworth, stripping may be postponed.

Driver: Drivers wishing to have their engines sealed may do so. It will require two people (one may be an official, the other a Scrutineer) to be present at the final stages of a build & it will incur a charge based on the time & distance travelled. If this option is taken at a major championship your engine will not require stripping, unless the seals have been broken. Seals can only be removed by Spedeworth officials & if they are removed without permission the engine / parts will be deemed to be illegal & the Driver suspended pending a Board of Control meeting. If any engine/ parts are sealed because Championship events are within a period, which may exclude that Driver due to a rebuild, the Driver with Spedeworth's agreement, postpone stripping for three meetings.

It is the Drivers responsibility to make provision for the sealing of the engine by drilling 1.5mm sealing holes in the following bolts / nuts & marked with red paint for identification purposes:

Either side of the Sump
Two Head bolts, if not covered wholly by a rocker / cam cover.
Two Inlet manifold bolts

Two Rocker / Cam cover bolts
The Bell housing
The Carburettor body and the mounting bolts / nuts

27. OIL CATCH TANK

1. An oil catch tank (no drink cans or bottles – minimum capacity of 0.5 litres) must be fitted in the engine bay.
2. The tank must have a minimum of 2 breather pipes connected to it: one from the rocker box and one from the crankcase.
3. Ineffective tanks during racing or practice will mean the car being withdrawn from the event.

28. COOLING SYSTEM

1. Radiators are free, but they must occupy their original position.

29. IGNITION SYSTEM - DISTRIBUTOR

1. Distributors must be the original manufacturer's part.
2. No electronic ignition unless it's fitted as standard.
3. The mechanical advance may be altered.
4. The vacuum advance unit must be fitted along with its vacuum hose, but it may or may not be working.
5. The distributor base plate attached to the vacuum unit must not be secured.
6. The Vauxhall OHC engine may use the Bosch distributor with contacts or the AC-Delco type with electronic ignition.

30. CARBURETTOR & INLET MANIFOLD

1. The Carburettor & venturi size, must be as listed in the table of eligible cars on page 2.
2. The Idle, Air Correction & Main Jets may be drilled to adjust the mixture strength only.
3. The Cold starting Choke Butterflies may be removed.
4. The Carburettor body must not be modified in any way and any economy devices must be fitted.
5. A secondary fixing is required on the Carburettor fuel inlet pipe if it is of the hose type.
6. Water circulation holes in the inlet manifold may be blanked off.
7. Exhaust manifolds with a Hot Spot under the Carburettor may blank it off.
8. Air filters may be removed.
9. No Ram pipes, Bell mouths or Stubs are allowed

31. FUEL SYSTEM

1. Fuel tanks must be metal or FIA approved & fitted inside the boot or rear area, but not below the chassis rails.
2. A complete fire wall must cover the tank and electric fuel pump.
3. The tank must have a maximum capacity of 18 litres.
4. Fuel caps must be of a metal screw type, no push fit types are allowed
5. The tank must have a positive means of fixing.
6. The fuel outlet must be from the top of the tank.
7. Fuel regulators are allowed.
8. An electric fuel pump can replace the mechanically one.
9. All fuel lines must be inside the car and be metal or metal covered.
10. A fuel shut off tap must be within easy reach of the driver.
11. A breather pipe must be fitted which should incorporate a one – way valve, with the pipe terminating below the tank so as to prevent spillage if inverted.
12. The tank should not be below the chassis rails so where a floor exists, four 50mm diameter holes should be drilled for drainage purposes.
13. Only roadside fuel can be used. No additives are allowed.

All Oval Racing Formulae

Permitted fuel specification from 1st January 2008 (this specification supersedes all previous specs).

- All cars must only use fuel from roadside pumps as defined below.
Petrol (Motor Gasoline of the type on sale to the general public from roadside filling stations) BS 4040 (Leaded) Subject to a valid permit for use. LRG (Unleaded), BS EN 228 (Unleaded), BS7800 (Super Unleaded).
- Petrol is a product refined from crude oil that contains a large number of identifiable compounds that can typically be 250 in number. These compounds can be identified and compared to the available petrol from major oil companies and suppliers.
- Unless otherwise stated, or the distinction is made between leaded and unleaded petrol, major gasoline fuel shall meet the following; Acceptance levels for Octane numbers will be determined at 95% confidence level. Only additives to this motor gasoline fuel solely for the purpose of lead replacement are allowed.
- Lead Replacement Gasoline, LRG, also known as LRP. Only additives from Sodium, Phosphorous, Potassium, or Manganese according to manufacturers recommendations are allowed. Note; Manganese can enhance octane values in any petrol. Under no circumstances will values in excess of 0.005 grams/litre be permitted.
Lead in excess of EU directive 98/70EC requirements is illegal.
- We reserve the right to amend the detail of the above specification to reflect any change occurring in the quality of the fuel on sale to the general public at any time.

Roadside fuel consistency when testing fuel samples.

	BS EN 228	BS 7800	BS 4040	LRG/LRP	Test Standard
Motor Oct No (max)	89.0	89.0	89.0	89.0	ASTM D2700/86
Mon (min)	85.0	86.0	86.0	86.0	ASTM D2700/86
Research Oct No (max)	100.0	100.0	100.0	100.0	ASTM D2699/86
Ron (min)	95.0	97.0	97.0	97.0	ASTM D2699/86
Lead (max)	0.005	0.005	0.15		ASTM D3341 / IP362
Lead (min)	ASTM D3237	ASTM D3237		0.005	ASTM D3237 / D3341 / IP362
Density @ 15°	0.720 - 0.775	0.720 - 0.775	0.720 - 0.775	0.720 - 0.775	ASTM D1298/ D4052
Oxygen % max	2.7% w/w	2.7% w/w	2.7% w/w	2.7% w/w	Elemental
Nitrogen % max	0.1% w/w	0.1% w/w	0.1% w/w	0.1% w/w	ASTM D4629/ IP379
Benzene % max	1.0% v/v	1.0% v/v	1.0% v/v	1.0% v/v	EN238
Sulphur	150mg/kg	150mg/kg	150mg/kg	150mg/kg	EN ISO 14596 / ASTM D2622
Olefins*	18% v/v	18% v/v	18% v/v	18% v/v	ASTM D1319
Aromatics*	42% v/v	42% v/v	42% v/v	42% v/v	ASTM D1319

* Olefins and Aromatics values are expressed as a percentage of total fuel.

32. EXHAUST SYSTEM

1. The exhaust manifold must be the standard one for the model of the car, not the engine.
2. Exhaust down pipes are free, but stainless steel types are not permitted.
3. You must use either the Ford E1ADDN5320A (an equivalent cross reference one is allowed) or the AX891 silencer.
4. There must be 254mm or 10" of tail pipe on the end of the silencer facing rearwards.
5. Any part of the system passing through the inside of the car must have heat shielding around it.
6. If your exhaust becomes ineffective in the last 5 laps of a race **you** must pull off, as you will be automatically removed from any results.

33. BATTERIES & THE ELECTRICAL SYSTEM

1. The Batteries must be securely fixed & covered with rot proof material if they are not of the sealed type.
2. No battery box only adequate clamping.
3. Battery position is free & a maximum of two batteries is allowed. Oversized batteries used for ballast are not permitted.
4. The Battery must be 152mm or 6" away from the fuel tank.
5. Contact between the safety harness & the Battery should not be possible
6. A battery master switch must be fitted in the rear left-hand window and clearly marked "ON-OFF" or have an electrical danger decal.
7. When an electric fuel pump is used, a cut off switch must be positioned within easy reach of the driver.
8. A self-starter motor must be fitted & working at all times.

34. TRANSPONDER

1. A Transponder is mandatory & it must be fitted 1.8m back from the front position of the car.
2. A hole 150mm or 6" in diameter or square, must be cut in the floor & the transponder fitted above it.
3. In the event of a dispute with a transponder result, then the Steward of the meeting will make the final decision.

35. MIRRORS

1. A rear view mirror is allowed.
2. Door mirrors if fitted must not protrude beyond the width of the vehicle.
3. Maximum size of the mirror is 152x100mm or 6x4" & it should be covered with a clear plastic film to prevent it shattering.

36. BODYWORK

1. Body shells & panels must remain as manufactured & must retain the original silhouette.
2. Front wings below the ironwork may be removed in front of the wheel.

37. PAINTWORK

1. The external appearance of the car must look professional at all times, drivers of scruffy looking cars will be told to improve their appearance & may not be allowed to race.
2. A maximum of two cars may be painted in team colours or painted to look similar, unless it is required by the Promoter for a particular team event.
3. 100% of the roof must be painted in the correct roof grading unless you are a Superstar or a current Championship holder, when the roof must be painted accordingly.
4. Sign writing must be professional and be approved by the Promoter.

38. SUN VISOR

1. A Sun visor 165mm or 6" in depth must be fitted with your name written upon it.

39. FIN PLATES

1. Fin plates must be fitted above the roof line but it should not be larger than 305mm or 12" by 559mm or 22" wide.
2. Fin plate numbers must be 229mm or 9" high by 38mm or 1½" in width, black numbers on a white background. Please ensure they are correct.

40. DOOR NUMBERS

1. The drivers racing number must appear on both sides of the car. The numbers should be 300mm or 12" high x 50mm or 2" wide, on a contrasting background, which must extend a minimum of 50mm or 2" beyond the numbers.

41. ROOF GRADING

1. All roof grade champions must start at the rear of the Grid, unless told otherwise by an official.
2. If you win a race at a meeting; you will start the remaining races from the rear of your grade. Should you win another race at the same meeting – you will be automatically upgraded.
3. Champions should start in the order of the list below, but multi-Champions will start next to the World Champion.

Grid Line up / Roof Order:

White (Novice)
Yellow
Blue
Red
Superstar (Red, White & Blue Stripes)
Silver Roof - Points Champion
White with Red Cross – English Champion
Gold Stripe – National Champion
Black & White Chequered – British Champion
Red & Yellow Chequered – European Champion
Gold – World Champion.

42. SPECIFICATION AND RULE CHANGES

The Promotion may at any time make amendments to the Specifications for the following reasons:

- In the interests of Safety
- Reduce costs for the driver
- In areas that are detrimental to the future of the formula
- If an unnecessary advantage has been deemed.

Current registered drivers will be notified automatically of any changes.

43. SCRUTINEERING OF NEW CARS

All new cars must be Scrutineered prior to its first meeting. Arrangements must be made with Spedeworth to bring the car along to a Stadium on the day of an event and then your car will be Scrutineered